

Work **Faster**
Less time waiting
for Lift & Lower

2 Stage Mast
FREE LIFT



WS12H-FL Electric Pedestrian Stacker

Lifting height: 2500-3500 mm / Load capacity: 1200 kg



**Variable Speed
Control**



Intelligent & Efficient



Rugged & Durable



Easy & Comfortable

STAX 

Variable Speed Control on Lifting & Lowering

Comfortable and efficient thanks to STAXX patented intelligent handle and control system, ideal for replacing manual & semi-electric stackers, for light use in narrow warehouse environments with efficient and easy pallet stacking.

The proportional lowering brings high efficiency for exact pallet placement and more precise control when compared to the normal fixed speed of lifting & lowering.

Variable speed control by proportional control knob, keeps lifting and lowering smooth, stable, safe and energy saving.

Lifting Height (mm)	2500	3000	3300	3500
Free lift (mm)	1300	1550	1700	1800

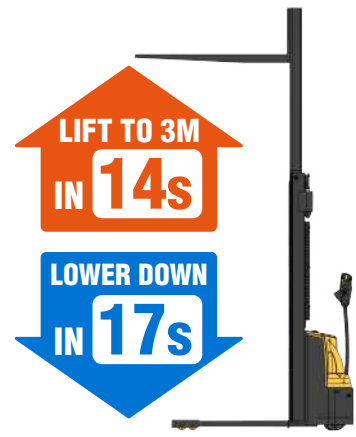
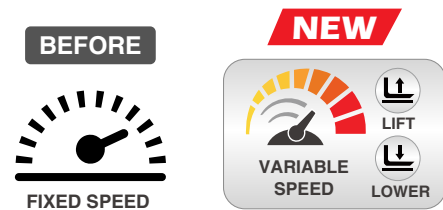

Precise Control

■ Proportional lifting & lowering

The variable speed control ensures the stacker goes up and down smoothly, minimizing the mechanical shock and vibration, ensuring fragile loads are gently placed on racking or the floor, and reducing the impact of noise and vibration on operators.

■ Lowering buffering

Automatic lowering speed descent with soft buffering when the fork height is lowered to around 10cm from the ground, effectively protects the safety of the cargo, low noise and small vibration.

■ High efficiency

The variable speed control brings accurate response for adjusting the lifting & lowering speed according to the actual situation, the operator can easily complete the task and improve the working efficiency.

■ Energy saving

Compared to the traditional fixed lifting & lowering speed, variable speed can be adjusted according to the load and height by operator, reducing energy waste and improving energy utilization rate.

■ Longer service life

Variable speed control can reduce the mechanical impact and friction during lifting & lowering, reduce the wear and tear on the chassis, mast, bearings, and enable a longer service life.



Intelligent & Efficient

Staxx patented multifunctional intelligent tiller handle is unique design for quick fault diagnosis, enabling an easier service, shorter service time and lowered labor costs.



Multifunctional intelligent tiller handle



Easy Maintenance

Serial communication technology

Single wiring harness communication from tiller handle to controller system. Simple, Durable and Stable.

UART

- ✓ Low after-sales service cost
- ✓ Quick & easy fault diagnosis
- ✓ Everyone can be an expert

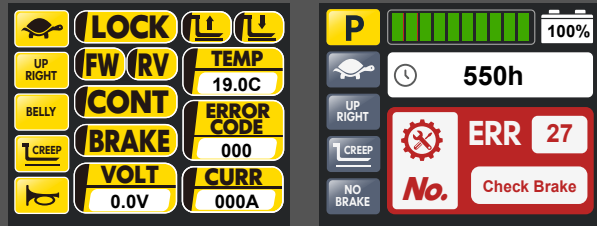

Operation status & fault diagnosis are integrated onto the tiller handle display for easy troubleshooting.

Operator Preferred

Turtle Speed — 01



Enable operator to choose different speed modes based on their experience and the specific work environment.

Up-Right Drive — 02



Easily maneuvered with the handle in the vertical position by pressing the turtle-speed button.

Engineering Mode (Brake Release) — 03



When truck is down, release the brake to move the unit manually.

Rugged & Durable

Due to a high-strength frame and mast design and solid materials used, the deformation of the frame, mast, and forks is small.



Longer service life

Mast: Standard C+H channel steel
 Frame: Steel plate thickness of 5mm
 Frame bottom plate: 30mm integrated steel plate



Double-chain design

Compared with single-chain design, it has higher strength, safer and more stable.

Small deformation of forks and masts, stable and durable

More stable when lifting & lowering with loads.

Full coverage protection on mast

Standard equipped with cylinder explosion-proof valve

It can prevent accidents such as uncontrolled descent caused by unexpected rupture of oil pipes, ensuring stable descent of the load and personal safety, and preventing damage to equipment.

Safe operation

Emergency reverse switch

In case of an emergency, it protects the operator and the surrounding personnel from harm.

Safety travel speed limit

When the fork is lifted to above 500mm, the driving speed automatically reduces to 2km/h to ensure the safety of operating at a high position in case of any misoperation.



Built-in charger

Hidden charging plug, high safety, the whole vehicle is powered off during charging, reducing safety hazards.

High lateral and longitudinal stability

Wider wheelbase and longer axle distance.

Adjustable balance wheel

Improved stability and maneuverability, suitable for different working scenarios.

The low ground clearance of 30 mm helps to reduce the risk of foot injuries

High-strength forks

The forks are formed in one piece with a thickness of 8mm steel. High strength and small deformation even under heavy loads.

The battery is fixed at the bottom of the frame

Improved stability.

Battery low voltage protection

Effectively avoid battery over-discharge, ensuring a longer battery life.

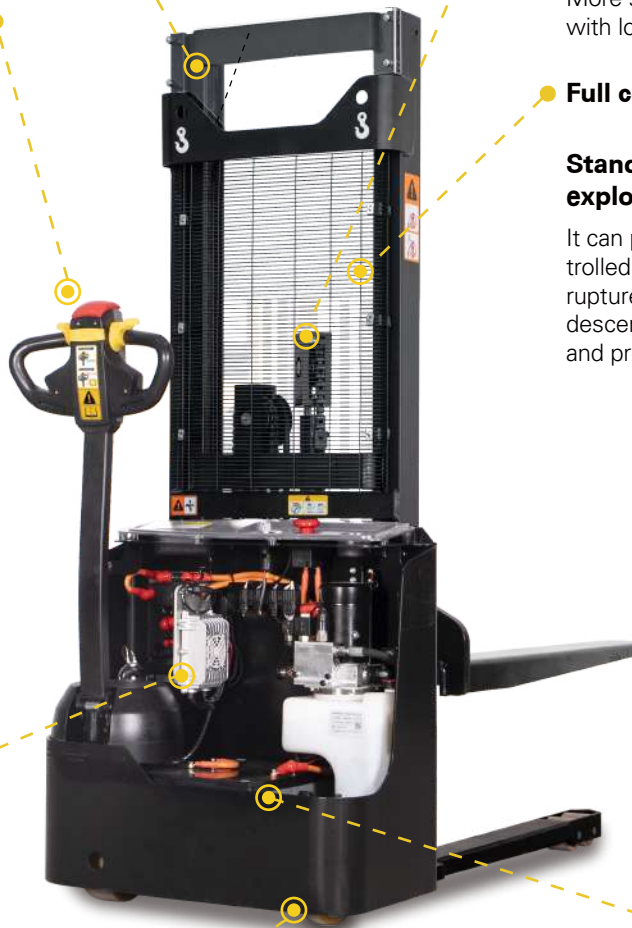

Easy & Comfortable



- **Effortless, easy to operate**

Low-mounted longer tiller reduces steering force required.

- **Low mast static height**

Easy to operate in containers and elevators with less than 3.3m lifting height.

- **The steering angle is designed to be above 180 degrees**

Small turning radius.

- **Excellent maneuverability**

Precise and maneuverable operating, high safety and efficiency.

- **Reasonable design of the balancing wheel eccentric distance.**

Flexible direction commutation

- **Easy to recharge**

Built-in charger and an external charging cable storage box for convenient charging.

- **Longer operating time**

Standard 24V/71Ah maintenance-free lead-acid battery, with the option of a larger capacity maintenance-free battery or a lithium battery.



Optional Configuration

- **Intelligent control**

Unique in the market and very suitable for sorting operations on trucks.

With a dedicated remote control device, the operator can control the forks to lift to the appropriate working height and carry out sorting operations, thus avoiding the need to use the handle buttons and bend over to pick up goods, improving operational efficiency and comfort.



- **Lifting button**
- **Lowering button**
- **Max speed setting button**
- **Horn button**



With the remote control device, you can easily set the speed suitable for the work, from level 1 speed to level 5 speed. Such speed transitions allow you to move the truck with controlled operation at ease.

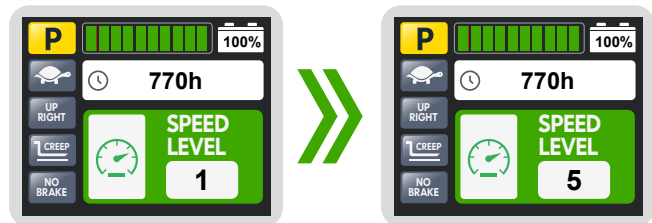

- **Reversing buzzer**

- **24V 60Ah(100Ah) LiFePO₄ Lithium battery**

- **24V/15A (30A) chargers**
Lithium Battery Charger
Charging time: 2~4 hours



Dimensions

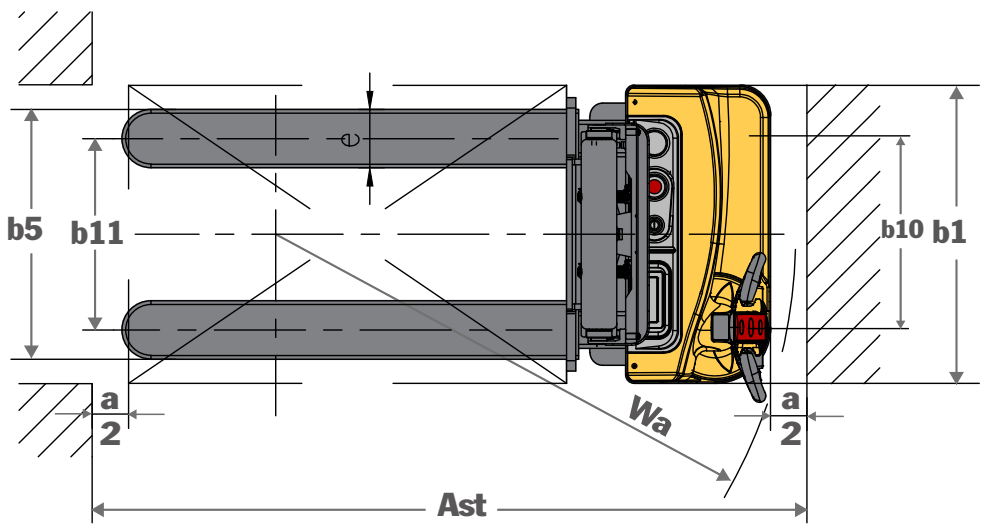
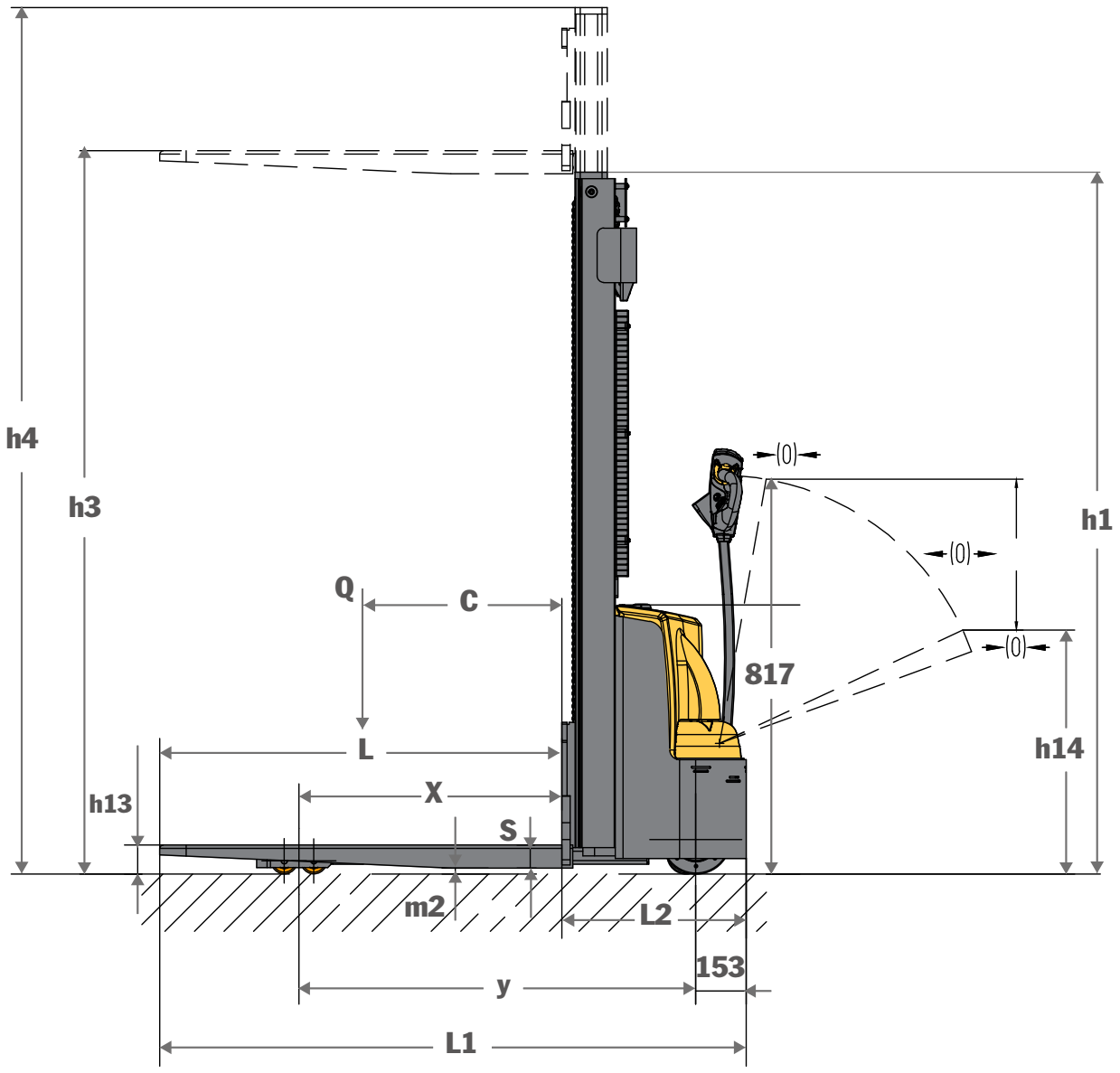

Specifications

MODEL				WS12H-FL			
DISTINGUISHING MARKS							
1.3	Drive						Battery
1.4	Operator type						Pedestrian
1.5	Load capacity/rated load	Q	kg				1200
1.6	Load centre distance	c	mm				600
1.8	Load distance, centre of drive axle to fork	x	mm				800
1.9	Wheelbase	y	mm				1210
WEIGHT							
2.1	Service weight (without battery)		kg	535.4	549.6	563.4	577.4
2.2	Service weight (with 71Ah battery)		kg	582	596	610	624
2.3	Service weight (with 89Ah battery)		kg	587	601	615	619
2.4	Axle loading, laden front/rear		kg			535/1247	
2.5	Axle loading, unladen front/rear		kg			437/145	
TYRES/ CHASSIS							
3.1	Wheels						Polyurethane
3.2	Wheel size, front	Ø x width	mm				Ø210x70
3.3	Wheel size, rear	Ø x width	mm				Ø80x70
3.4	Additional wheels (dimensions)	Ø x width	mm				Ø115x55
3.5	Wheels, number front/rear (x = driven wheels)						1x + 1 / 4
3.6	Tread, front	b10	mm				555
3.7	Tread, rear	b11	mm				400(560 fork width)/520(680 fork width)
DIMENSIONS							
4.2	Lowered mast height	h1	mm	1710	1960	2110	2210
4.3	Free lift height	h2	mm	1300	1550	1700	1800
4.4	Lifting height	h3	mm	2500	3000	3300	3500
4.5	Extended mast height	h4	mm	2917	3417	3717	3917
4.9	Height of tiller in driving position, min./max.	h14	mm			910/1270	
4.15	Height, lowered	h13	mm			90±2	
4.19	Overall length	l1	mm			1730(1150 fork)/1800(1220 fork)	
4.20	Length to face of forks	l2	mm			560	
4.21	Overall width	b1	mm			820	
4.22	Fork dimensions	s/e/l	mm			70x160x1150(1220)	
4.25	Width over forks	b5	b5(mm)			560/680	
4.32	Ground clearance, centre of wheelbase	m2	m2(mm)			30	
4.34.1	Aisle width for pallets 1000 × 1200 crossways	Ast	Ast(mm)			2268	
4.34.2	Aisle width for pallets 800 × 1200 lengthways	Ast	Ast(mm)			2194	
4.35	Turning radius	Wa	Wa(mm)			1425	
PERFORMANCE DATA							
5.1	Travel speed, with/without load		km/h			4/4.5	
5.2	Lift speed, without load		mm/s			0-220/Free lift, 0-208/After free lift	
	Lift speed, with load		mm/s			0-125	
5.3	Lowering speed, without load		mm/s			26-145/Free lift, 26-245/Before free lift	
	Lowering speed, with load		mm/s			28-165	
5.8	Max. gradeability, with/without load		%			5/10	
5.10	Service brake						Electromagnetic
ELECTRIC-ENGINE							
6.1	Drive motor rating S2 60 min		kW			0.75	
6.2	Lift motor rating at S3 15%		kW			2.5	
6.4	Battery voltage/nominal capacity (C5)		V/Ah			● 12/71 x 2 ○ (12/89) x 2	
6.5	Battery weight +/- 5%		kg			● 23.2 x 2(71Ah)/ ○ 25.8 x 2(89Ah)	
6.6	Energy consumption according to EN 16796		kWh			0.4	
ADDITION DATA							
8.1	Type of drive control						DC seed control
8.4	Sound level at the driver's ear according to EN 12053		dB(A)			<75	

Note: 1kgs=2.2lbs, 25.4mm=1inch

● standard ○ option

MAST DIMENSIONS					
WS12H-FL		Duplex Mast			
Lowered mast height	mm	1710	1960	2110	2210
Free lift height	mm	1300	1550	1700	1800
Lifting height	mm	2500	3000	3300	3500
Extended mast height	mm	2917	3417	3717	3917

LOAD CHART

