

## CONFIGURATION

Overhead Guard (12T)	Adjustable Steering Column
Cabin with Electric Fan(16T)	High Level Exhaust
	Rear Working Lamp
	Working Warning Light
Pedal Rubber	Oil Pressure Warning
Suspension Seat	Electric Horn
Automatic Shift	LED Signal Lamp
Electro-hydraulic Reversing	Lifting/Tilting/Positioning Joysticks
Wide Field Mast (2 Stage)	Full-hydraulic Power Steering
Fork Positioner (12T/135/160DT-A)	Tilting Cylinder Latching Valve
Sideshift & Positioner (160DT-B)	Transmission Oil Filter
Combination Instrument	Hydraulic Return Filter
Working Hour Meter	Push-button Parking Brake
Oil Content Meter	Driving OPS (12T)
Water-thermometer	
Key Shutoff Device	Traction Pin
Neutral Position Switch	Tool Box
Power Master Switch	

## OPTIONAL

Cabin(12T)	Solid Tires
A/C(12T/16T)	Oil Bath Air Filter(16T)
Rear Camera(16T)	Sound-light Alarm
Warm-air Blower	Fire Extinguishing Muffler
Front Windscreen	Lengthen Fork Jacket
Torque Converter Oil Temperature Alarm	Tilting Cylinder Sleeve
	Steering Cylinder Sleeve
Overspeed Alarm, 10km/h	Custom Colors
Electric Fan(12T)	Multiple Work Attachments
Full Set LED Lamps	

## PRODUCT FEATURES

<p><b>Good Heat Dissipation</b> Cooling system is reasonable optimized, which improves cooling performance significantly. Thus improving reliability and durability of key components such as gearbox and engine.</p>
<p><b>Lowering Energy Consumption</b> Optimized design of hydraulic system. Adopt domestic or foreign mature hydraulic parts, reduce fuel consumption.</p>
<p><b>Operating Comfort</b> Adopted interactive ergonomic design to improve operating comfort. Equipped with wide field of view mast to improve driver's field of view. Multiplex valve of 16T adopt pilot control. Mast has good final motion performance.</p>
<p><b>Intelligent Reversing</b> Electro-hydraulic Reversing System. Easy to operate and labor-saving. Intelligent shift system prevent the second gear starting, ensure reliability of gearbox.</p>
<p><b>Convenient Maintenance</b> Interior space of car body is more spacious. Parts Positions are more reasonable. ZF and DANA gearboxes adopt TCU control with fault diagnosis to simplify maintenance. (LG160DT-B)</p>
<p><b>High Reliability</b> Strength of the core structural parts of car body, mast and hood has been enhanced greatly to make whole vehicle more solid.</p>

The following blank can be used for notes or comments.

**For more information on Lonking products,  
Please contact our local agent:**

Lonking, Lonking LG Series and their respective logos, as well as corporate identity in this leaflet are trademarks of Lonking Holdings Ltd., and may not be used without written permission.  
2020/06

Specifications and design are subject to change without prior notice.  
Machines shown may not include optional accessories.

# LONGKING 龙工

## LG120DT/135DT/160DT(A)/160DT(B) BALANCEWEIGHT TYPE FORKLIFT TRUCK WITH ENGINE Efficiency Rules the Future



LONGKING (FU JIAN) INTERNATIONAL TRADE CO., LTD.

**LONGKING HOLDINGS LIMITED**

Add: 26 Minyi Road, Xinqiao, Songjiang Industrial Zone, Shanghai

Tel: +86-21-3760 2242 E-mail: export@lonking.cn

<http://www.lonkinggroup.com>

	LG120DT	LG135DT	LG160DT(A)	LG160DT(B)
Rated Capacity (kg)	12000	13500	16000	16000
Load Center (mm)	600	600	900	1200
Power Type	Diesel	Diesel	Diesel	Diesel

## OVERALL SPECIFICATIONS

Type	No.	Item	Code	Unit	Data			
Identification	1.01	Manufacturer			LONKING			
	1.02	Model			LG120DT	LG135DT	LG160DT(A)	LG160DT(B)
	1.03	Power type			Diesel			
	1.04	Rated capacity	Q	kg	12000	13500	16000	16000
	1.05	Load center	J	mm	600	600	900	1200
Dimensions	2.01	STD Max height (with backrest)		mm	4668	4700	5425	5685
	2.02	STD Max lifting height	h1	mm	3000	3000	3500	4000
	2.03	Overhead guard height	h4	mm	2610	2974	3566	3262
	2.04	Overall length (with fork)	L1	mm	5945	6712	7410	7870
	2.05	Wheelbase	L2	mm	2950	3250	3800	3750
	2.06	Front overhang	L3	mm	755	785	968	925
	2.07	Rear overhang	L4	mm	720	857	840	795
	2.08	Min.ground clearance (Frame/Mast)	m1/m2	mm	360/266	280/276	330/330	250/250
	2.09	Overall width	W1	mm	2350	2740	2752	2560
	2.10	Adjusting range of fork (outside)		mm	470-2200	470-2380	580-2214	900-2340
	2.11	STD Fork size (L5*W*T)		mm	1520×200×85	1820×200×85	1820×220×100	2400×250×100
	2.12	Front wheel tread	S	mm	1724	2068	1895	1878
	2.13	Rear wheel tread	P	mm	1850	2120	2120	2120
	2.14	Min.turning radius	R1	mm	4300	4500	5300	5175
	2.15	Min aisle width for pallet 1000×1200,crossways		mm	6775	7300	8288	8700
	2.16	Min aisle width for pallet 800×1200,lengthways		mm	6775	7300	8288	8700
Tires	3.01	Wheels number, front/rear (X=driven wheels)			X=4/2			
	3.02	Tires type			Pneumatic			
	3.03	Tires size, front			10.00-20-16PR	11.00-20-18PR	12.00-24-20PR	12.00-24-20PR
	3.04	Tires size, rear			10.00-20-16PR	11.00-20-18PR	12.00-24-20PR	12.00-24-20PR
Other Details	4.01	Max.traveling speed, loaded/unloaded		km/h	25/27	25/27	22/27	26/29
	4.02	Max.lifting speed, loaded/unloaded		mm/s	350/370	360/400	280/300	320/360
	4.03	Lowering speed, loaded/unloaded		mm/s	350/310	410/320	410/320	360/310
	4.04	Max.traction, loaded		KN	85	85	110	130
	4.05	Max.gradient, loaded/unloaded		%	25/20	25	20	28/25
	4.06	STD operating weight (with oil & water)		kg	15300	18000	23500	24000
	4.07	Axles loading,front/rear (loaded)		kg	24900/2400	36500/3000	36500/3000	37200/2800
	4.08	Axles loading,front/rear (unloaded)		kg	7200/8100	10500/13000	10500/13000	11700/12300
	4.09	Service brake			Gas push oil-pedal		Wet brake-pedal	
	4.10	Parking brake			Mechanical-hand brake lever		Hydraulic release-push-button	
	4.11	Drive type			Hydraulic gearbox	Electrical gearbox	Electrical gearbox	Automatic-DANA
	4.12	Number of gear (front/rear)			2/2	2/2	2/1	3/3
	4.13	Fuel tank capacity		L	200	200	300	250
	4.14	Battery votage/capacity		V/Ah	2×12/90	2×12/90	2×12/120	2×12/120

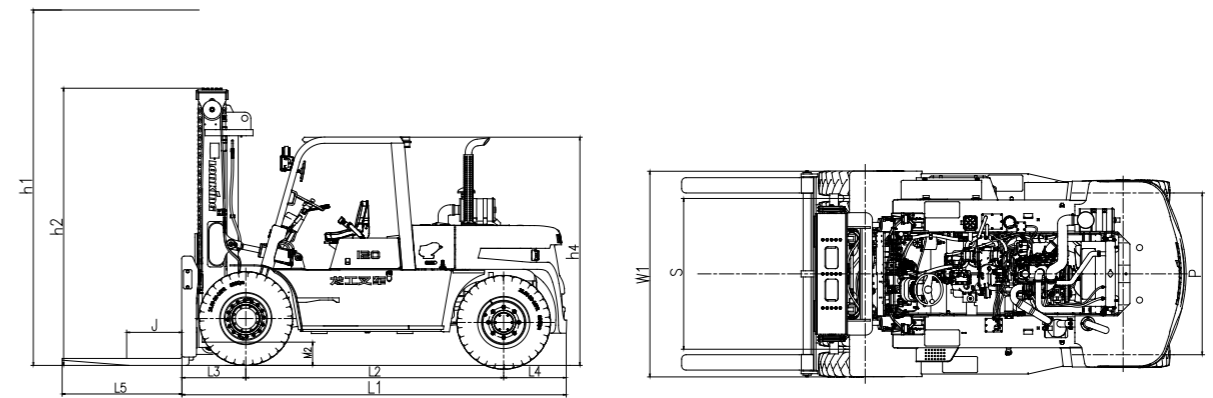

## MAST SPECIFICATIONS

### 2 Stage Standard Mast-Super Wide Field

Mast Model	h1 Max Lifting Height(mm)	Load Capacity (Load centers see parameter)				h2 Lowered Mast Height (mm)				Free Lifting Height(mm)	Mast tilt α/β (°)			
		12T	13.5T	16T(A)	16T(B)	12T	13.5T	16T(A)	16T(B)		All	12T	13.5T	16T(A)
M300	3000	12000	13500	16000	16000	3168	3200	3425	3185	/	6/12	6/12	5/10	/
M330	3300	12000	/	16000	/	3318	/	3575	/	/	6/12	/	/	/
M350	3500	12000	13500	16000	16000	3418	3450	3675	3435	/	6/12	6/12	5/10	5/10
M370	3700	12000	/	16000	/	3518	/	3775	/	/	6/12	/	/	/
M400	4000	12000	13500	16000	16000	3668	3700	3925	3685	/	6/12	6/12	5/10	5/10
M450	4500	11500	13500	15500	15500	3968	3950	4225	3935	/	6/6	6/12	5/10	5/10
M500	5000	11000	13500	15000	15000	4218	4200	4475	4185	/	6/6	3/6	5/6	5/6
M550	5500	10500	12500	14500	14500	4498	4450	4755	4435	/	6/6	3/6	3/6	3/6
M600	6000	10000	11500	14000	14000	4748	4700	5005	4685	/	6/6	3/6	3/6	3/6

### LG120DT-3 Stage Free Mast-Super Free Lifting Height

Mast Model	h1 Max Lifting Height(mm)	Load Capacity (J=600mm) (kg)	h2 Lowered Mast Height (mm)	h3 Free Lifting Height, without backrest (mm)	Mast tilt α/β (°)
ZSM450	4500	11500	2845	1575	6/6
ZSM500	5000	11000	3025	1755	6/6

## ENGINE OPTIONAL

Engine Optional							
Engine Model	Emission	Manufacturer	Rated Power	Max.Torque (N.m/rpm)	Bore/Cylinders Number/Displacement	Fuel Consumption	Applicable
CA6DF3-16GAG3U	CHN III	XICHAI	118kW/2200rpm	640/1300-1700	110/6/7.127	230kg/kW.h	LG120/1350DT
QSB4.5-C160	Euro IIIA	CUMMINS	119kW/2200rpm	624/1500	107/4/4.5	230kg/kW.h	LG120DT
YC6J175-T302	CHN III	YUCHAI	129kW/2200rpm	710/1400-1700	105/6/6.494	230kg/kW.h	LG160DT(A)
WP6G190E330	CHN III	WEICHAI	140kW/2200rpm	760/1400-1600	105/6/6.75	225kg/kW.h	LG160DT(A)
QSB6.7-C190	Euro IIIA	CUMMINS	142kW/2300rpm	930/1500	107/6/6.702	230kg/kW.h	LG160DT(B)

